

THE MEASUREMENT OF GAS CALORIFIC VALUE USING RESIDUAL OXYGEN TECHNIQUES

David Hailey
Product Manager
Cosa Instrument
7125 North Loop East
Houston, TX 77028

Robert E. Preucil
Division Manager
Cosa Instrument
7125 North Loop East
Houston, TX 77028

David Keebler
I/E Specialist
Air Liquide
2120 Victoria Street
Freeport, TX 77541

KEYWORDS

Combustion Air Requirement Index (CARI), Wobbe Index, Fuel Gas,
Stoichiometric Air to Fuel Ratio, Requirement, Air/Fuel Ratio CARI Index,
40 CFR 60.18

ABSTRACT

This paper describes a gas calorimeter that measures CARI Index, Wobbe Index and calorific value of a gas on a continuous basis without the use of a flame. Instead, the gas is oxidized in a catalytic converter and the residual oxygen from the reaction is correlated to the measurement of interest. This technique offers the extremely fast speed of response and reliable measurements over large calorific value turndowns without the concern of flameouts. The theory of operation, alternate measuring techniques, test data and results of installations in petrochemical plants on flare gas applications and feed forward process applications are to be presented. Emphasis will be placed on configurations developed to satisfy Environmental Protection Agency air emission standard 40CFR60.18

INTRODUCTION

Gas Calorimeters offer several unique advantages compared to chromatographs when one needs to measure the amount of energy in a gas. First, the calorimeter burns all combustible components in a stream, regardless if their presence is anticipated or not, and second, is a continuous measurement. This is significant, especially when the gas has widely varying chemical compounds contributing to

the stream, and when the measurement is used as a feed forward signal for blending varying fuels used in a combustion process.

The basic components of a gas calorimeter are the Fuels Conditioning Section, where the gas to be measured is properly blended with air, the Combustion Section, where the mixed gas and air are reduced down to its elemental state, and the Measurement Section, where the device measures the heat released from the mixed gas and correlates it to CARI Index, Wobbe Index and calorific value (BTU's/SCF, or Joules/meter)

COMBUSTION BASICS

Stoichiometric reactions are ones in which a mixture of reactants are exactly proportioned on a molal basis so that no excess of any reactant is present after the reaction. A Stoichiometric combustion is one in which all the oxygen atoms and fuel molecules are chemically reacted (oxidized). More plainly put, it is the point where just enough oxygen is present to burn all of the combustible reactants in the stream. Carbon (C) to carbon dioxide (CO₂), hydrogen (H) to water vapor (H₂O) and all sulfur (S) to sulfur dioxide (SO₂). The basic chemical equation for combustion of a fossil fuel is

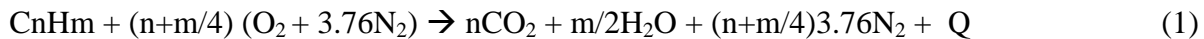

Where C_nH_m is a fossil fuel, with “n” the number of Carbon atoms in the reaction, and “m” the number of Hydrogen atoms.

O₂ + 3.76N₂ is air, which is used as the source of oxygen.

Q is the heat released from the combustion process.

To assure complete combustion of a fuel, a combustion process is run at higher oxygen levels than needed to theoretically burn all of the fuel. This extra amount is called excess oxygen, or because air is used, excess air. In most combustion processes, excess O₂ is generally measured to assure all fuel is burned. Standard practice is to use a zirconium oxide analyzer to perform this measurement.

FUELS CONDITIONING SECTION

The Fuels Conditioning portion of a Gas Calorimeter is comprised of a continuous gas sample that is mixed with dry air and maintained at a constant temperature and ratio determined by Air/Gas orifices in the mixing chamber (Figure 2). The gas and air stream pressures are first equalized by a dome loaded pressure regulator. These streams are then temperature regulated. The flow to their respective orifice plates are regulated at critical flow rates, and then fed to a mixing chamber creating a homogeneous mixture of the gas and air. Specific gravity of the process gas is measured when calorific value needs be reported in BTU/SCF, or MJ/NM³ for various gas blending, flare gas, feed-back or feed-forward applications.

An alternative to using orifices to meter the gas and air streams is to measure the flows using mass flow meters. This adds some complexity to the fuel conditioning section but does have the advantage of eliminating the need for a specific gravity measurement when BTU/SCF is to be reported.

COMBUSTION SECTION

Now that the fuel is properly mixed with a reducing agent (air), it must be burned, or oxidized in order to determine the heat contained in the gas. There are three main types of methodologies employed for measuring the released heat.

The first type utilizes a thermopile to measure changes in the combusted gas temperatures from an internal burner assembly. A thermopile is several thermocouples joined together to detect very minute changes in the exit combustion gas temperature. Ambient air is drawn into a combustion chamber with a fan which is used to mix the combusted flue gases. The temperature is measured by the hot and cold junctions of the thermopile, which can be related to Wobbe Index or Calorific Value. This methodology is very sensitive to ambient temperature changes and requires a climate controlled environment to maintain accuracy. An ambient temperature change of as little as 5 deg C can cause significant measurement errors.

Because of the limited turndown of the burner assembly, large calorific changes in process gas often result in the need to blend additional fuel (high purity assist gas) with the process gas stream to eliminate flameouts. This adds complexity and the need to perform additional calculations to the analyzer's output to arrive at the desired measurement. Should the burner flame go out due to low calorific values maintenance personnel would need to restart and check the system..

Another way to measure the heat release is to route the exhaust gas of a burner assembly past an expansion bar. The expansion bar is simply a piece of metal whose expansion and contraction are measured and correlated to Wobbe Index or calorific value (when specific gravity is measured). This is an inexpensive approach to measuring the heat release, but speed of response suffers and its sensitivity to ambient temperatures affects accuracy. Here as well, an additional fuel (high purity assist gas) is added to the process gas stream to eliminate flameouts when low calorific value process gas is to be measured, which adds complexity in calculating calorific values.

Both the first and second measurement methodologies offer a substantially faster response time than that of a traditional Gas Chromatograph. These methods are also well suited to providing Natural Gas values for energy accounting and custody transfer when equipped with an optional specific gravity cell. But in applications where the speed of response is critical, as in gas blending, process control, flare gas applications or where a traditional climate controlled measurement building is not available they fall short in comparison to another methodology available.

The third methodology is the residual oxygen measurement. This is a flameless technology that measures the excess oxygen from a continuous stream of sample gas which is oxidized in a catalytic converter. The sample gas and air mixture from the Fuels Conditioning System is catalytically

combusted in an oven (Figure 2) whose temperature is set to approximately 812°C and by a thermocouple and PID algorithm programmed in the microcontroller.

The air to fuels ratio is calculated to select the AIR/GAS orifices in the mixing chamber (Figure 2) so that there is always an excess of oxygen in the exhaust gas. The measurement of excess oxygen provides a direct measurement of the Combustion Air Requirement Index (CARI) of the fuel, which can then be mathematically correlated to the Wobbe Index. Differences between the CARI and Wobbe Index values can be cancelled out by the use of calibration gases thus giving this technique the ability to report Wobbe Index values along with CARI. With the addition of a Specific Gravity Cell, BTU/SCF can be reported as well (Figure 1).

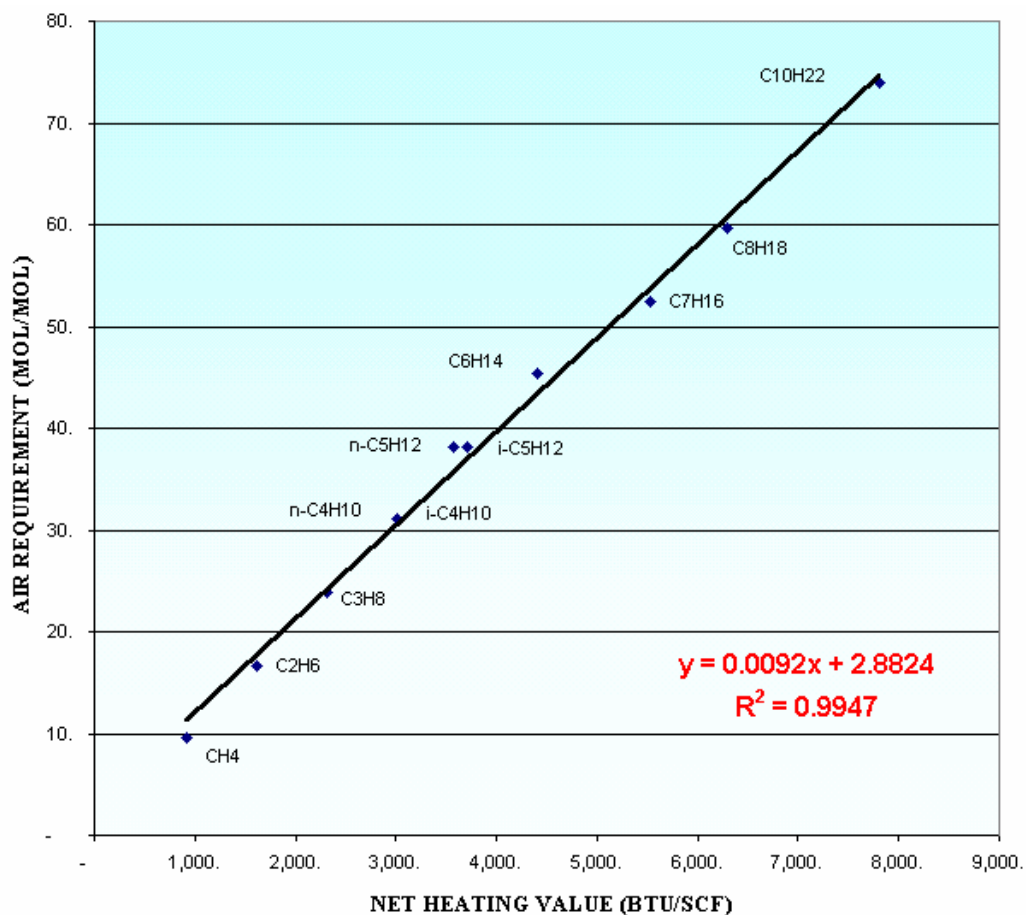

FIGURE 1 CORRELATION BETWEEN HEATING VALUE & STOICHIOMETRIC AIR REQUIREMENT

This methodology does not suffer from ambient temperature effects as do most other approaches, minimizing or eliminating measurement shelter and associated building and utility costs. There is no flame to go out, so during a low calorific value event the system never shuts down, disrupting plant operation or require a call out service. The constant flow of sample gas allows for a fast speed of response to changing calorific values. This methodology has very low maintenance requirements when compared to the other methodologies with regard to repair, operation, setup, down time and field service.

There is also the added advantage of being able to measure extremely high dew point gases that require the sample gas and analyzer enclosure to be to as much as 95°C to keep the sample gas in a gaseous state. Thus, high BTU gas can be measured without the concern of “heavy” hydrocarbons condensing.

HEATING VALUE MEASUREMENT OF FLARE GAS

According to the EPA, Flares shall be designed for and operated with no visible emissions as determined by the methods specified in 40 CFR 60.18, except for periods not to exceed a total of 5 minutes during any 2 consecutive hours. Flares shall be operated with a flame present at all times, as determined by the methods specified. Flares shall be used only with the net heating value of the gas being combusted being 11.2 MJ/NCM (300 BTU/SCF) or greater if the flare is steam-assisted or air-assisted; or with the net heating value of the gas being combusted being 7.45 MJ/NCM (200 BTU/SCF) or greater if the flare is non assisted. The purpose of this rule is to limit the emissions of volatile organic compounds (VOC's) by maintaining a minimum heating value at the burner tip, combined with auxiliary fuel, and steam or air to promote mixing for a nearly complete (> 98%) VOC destruction.

Further, all flares with the potential of emitting highly reactive volatile organic compounds (HR-VOC's) listed in the regulation, must measure and report these components and report them along with the calorific value. This task is generally performed by a process gas chromatograph. The gas chromatograph can also measure and report calorific value by measuring everything in the stream and then calculating the calorific value based on the stream composition. This, however, adds complexity to the GC, which increases its initial cost as well as its long term cost of ownership. The GC must be configured to measure all components in the stream, a challenging task on a flare whose feed stock may have unanticipated waste dumped into the system.

Use of the residual oxygen measurement method as found in the Residual Oxygen Calorimeter technology (Figure 2) is advantageous in many respects to flame technologies for low Btu, Wobbe or CARI applications. The 200 to 300 BTU/SCF EPA requirement does not represent a potential flame-out condition to the zirconium oxide cell, nor does the ZrO₂ require any special auxiliary gasses (high purity assist gas) to stay lit and operational during the critical measurement period due an upset condition.

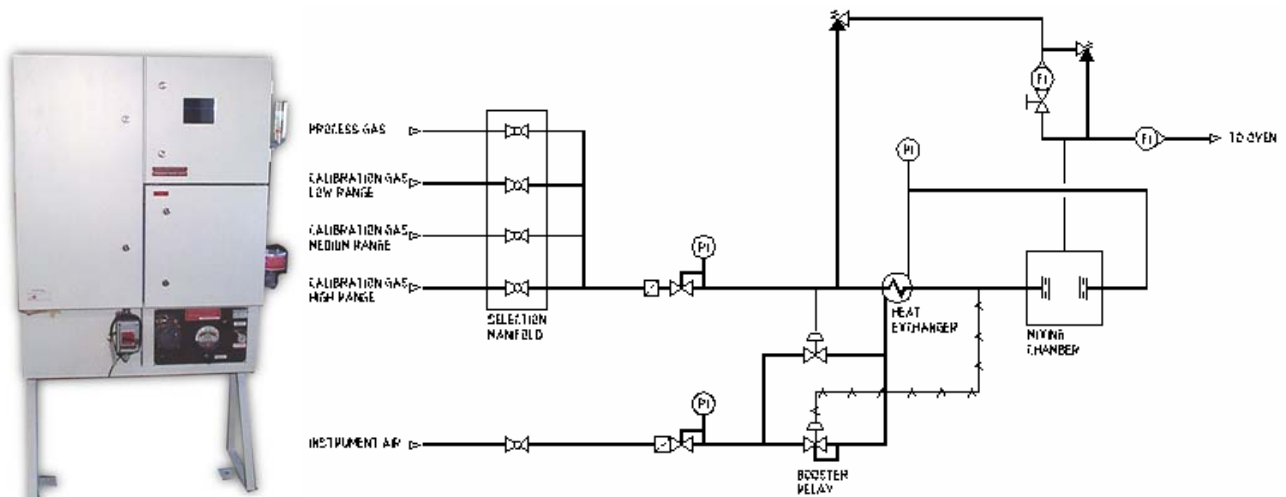

FIGURE 2 RESIDUAL OXYGEN CALORIMETER

SPEED OF RESPONSE

Speed of response is another critical factor for installations in petrochemical plants or flare gas applications and feed forward process applications.

The speed of response can also be a major design factor in many control processes. This is very evident in process control applications such as gas blending, fuel air optimization, turbine control as well as flare stack monitoring and control. A few seconds difference in response can be costly due to wasted assistance fuel to flare stacks (when the feed gas falls below the required 200 to 300BTU/SCF), or to maintain a precise gas blending ratio.

In 2002, a HYCO plant needed to install three calorimeters to measure the Btu content of the gas being brought into the plant as its feed stock. Speed of response was critical as slow measurements would not accurately capture the calorific value of the purchased gas. This could have led to process optimization errors and thousands of dollars in billing errors per month.

Figure 3 shows the results of actual testing for speed of response of the Residual Oxygen Calorimeter technology and two other Flame Calorimeter Technologies. The Residual Oxygen Calorimeter provided a T90 of 5 seconds as opposed to Flame Calorimeters providing T90's of 14 seconds (thermopile sensing technology) and 18 seconds (expansion bar sensing technology) respectively.

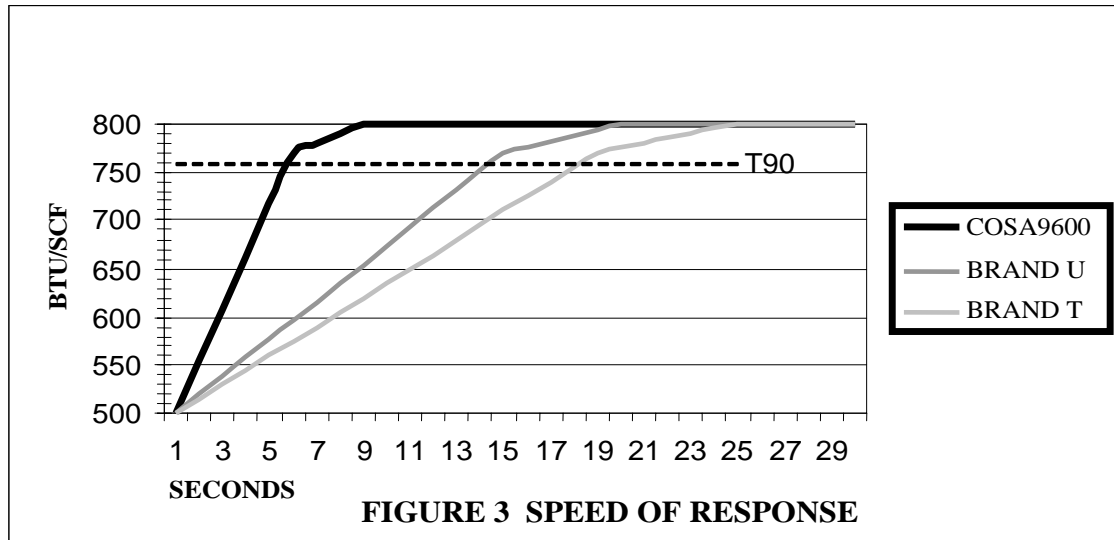

CONCLUSIONS

The use of the residual oxygen measurement method gives several advantages in the following areas:

- Low Btu and flare applications
- Speed of response is important and represents savings
- Minimal user intervention is required
- Lower maintenance and low cost of ownership are needed

REFERENCES

1. Princeton University Thermodynamics - Stoichiometric Combustion
http://www.princeton.edu/~humcomp/sophlab/ther_41.htm
2. Department of Environmental Protection (EPA) – Flare Gas, 40 CFR 60.18
<http://www.dep.state.fl.us/air/permitting/writertools/t3nsps/60flares.doc>
3. Department of Environmental Protection (EPA) – VOC Destruction Controls
<http://www.epa.gov/ttn/catc/dir1/cs3-2ch1.pdf>
4. Taftan Data - Stoichiometric Combustion
<http://www.taftan.com/thermodynamics/combust.htm>
5. Engineering Thermodynamics, Thermodynamics of Reacting Mixtures, Reynolds and Perkin, McGraw Hill Publishing